



KUZMA STABI S TURNTABLE
(with Stogi S tonearm and CAR cartridge).....

Instruction manual

2021-4

KUZMA LTD

INSTRUCTION MANUAL FOR STABI S turntable

The **Stabi S** turntable is a very precisely engineered piece of equipment. The construction, however, is robust and requires little maintenance for optimal performance.

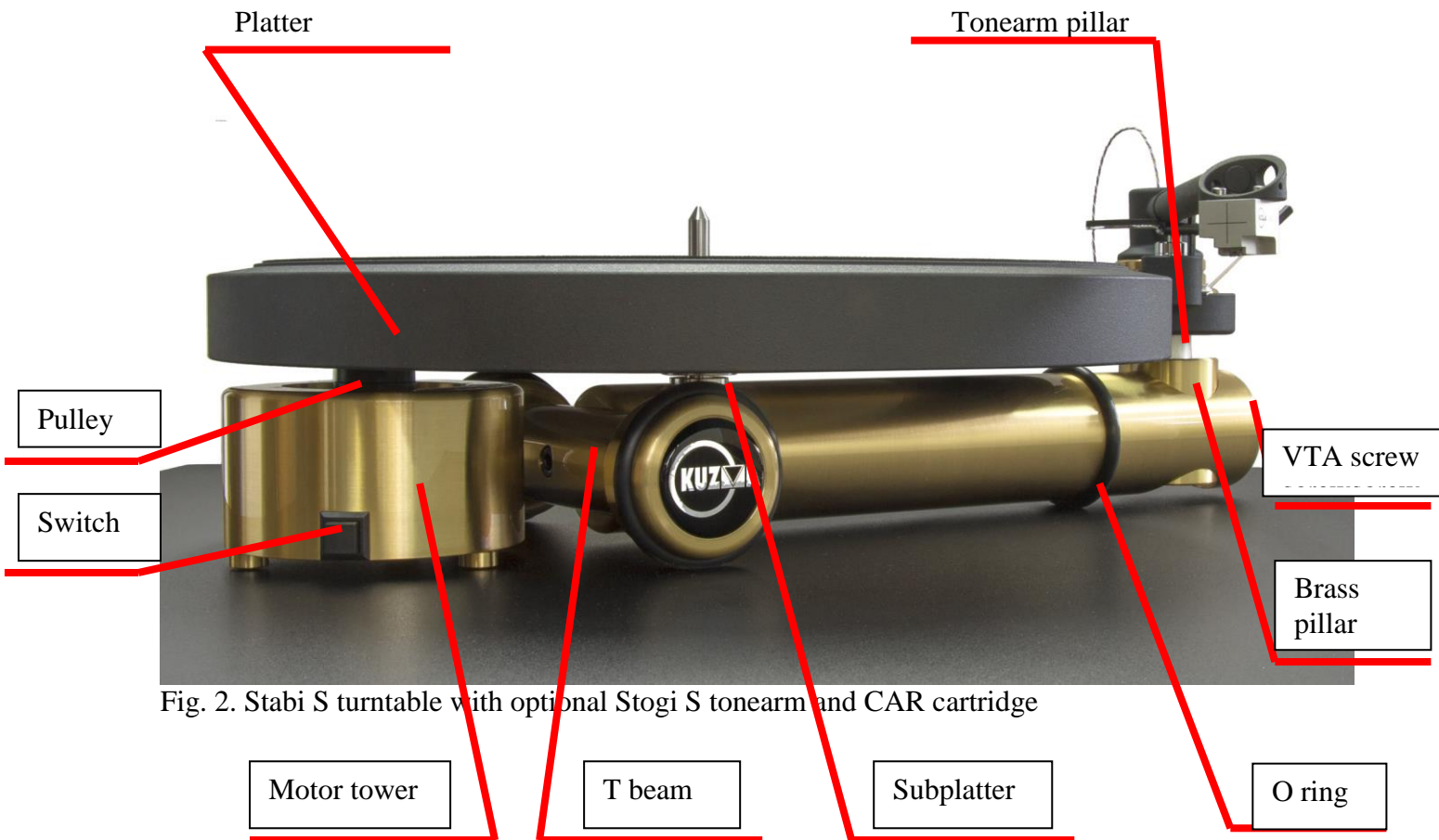

CONTENTS:	Page
General & warranty	3
Unpacking	4
Basic Setup	5-6
Turntable set up	6
Use and adjustment	7-8
Maintenance-upgrades	8
Troubleshooting	9

General Description:

The turntable is packed in one box on which is indicated whether a Stogi S tonearm is included, or an armboard for a different tonearm.

The basic approach to the turntable design was the same as that of all our products. Its unique shape and construction from solid brass rods, provide an extreme rigid connection of platter, bearing and tonearm support. The motor is housed independently in its own tower which dampens motor vibration. The bearing is of highly polished, fine grain carbon steel with a one point contact, while the bearing sleeve is of a resin/textile material which has excellent damping, non-resonant and high sliding properties. With the mat on top and rubber insert underneath, the platter provides a stable non - resonant platform for records, which can also be clamped.

A 45 rpm adaptor is provided and is simply slipped over the 33 rpm motor pulley. The turntable can accommodate various tonearms by the use of different brass bases and allows for VTA adjustment on any tonearm mounted. It is possible to add a second tonearm if a special adaptor (available as an optional extra) is added.

Product registration and warranty extension

Kuzma products has a non transferable 2 year limited warranty on parts and labour varied by dealer/distributor in specific country.

To achieve 5 years* limited warranty from us, you need to register product on our web site within 30 days of purchase.

We suggest to register products in any case because this will also help you to easier receive our technical support and with resale product's warranty.

Simply register on our web site and fill the requested forms and you will receive in a few days extended five year warranty card on your email. * not valid for ex demo products.

Technical data:

Mass:	13 kg
Platter:	4, 8 kg
Motor:	AC synchronous
Speeds:	33, 45 rpm
Dimension:	400x 300x 140 mm
Power and frequency:	see motor base

Optional: clamp, wooden platforms, various armboards, adaptor for second tonearm (SD), external power supply, 12 inch tonearm mount

Safety Precautions:

Electrical connection to the mains comes from the motor assembly via the cable. Please keep the motor assembly away from moisture and be careful not to damage the mains cable. If in doubt consult your dealer.

Unpacking:

The whole turntable with tonearm (if supplied) is packed in one box. Before unpacking the individual parts of the turntable, prepare the area where the unit will be situated. The best position is on a solid shelf which is strong and rigid enough to support the turntable. For best performance this should be completely horizontal.

Contents:

Instruction manual, lid, T base, motor tower, oil bottle, belt, 45 rpm crown pulley, allen key 3 mm, subplatter, platter

Optional:

Stogi S tonearm with its own accessories

Clamp (in box- see Fig 3)

Wooden platform (on top of the box)



Fig. 3 Unpacking: T base and parts .



Fig. 4 Unpacking: subplatter



Fig. 5 Unpacking: platter

Basic setup:

Note: Carefully unpack parts which are in protective plastic bags.

Note: When assembling the motor tower and platter, ensure that the platter will not touch or damage the motor pulley! Check the distance of the motor tower from the T base.

Note: While the parts are packed in plastic bags for protection, these are not intended to be strong enough to lift or carry the parts.

Lid:

If the turntable is supplied with a wooden platform, remove this and place in position. The rounded part should be on the left. Locate the three small holes which correspond to the intended position of the three black rubber rings on the main T base. If the turntable is supplied with Stogi S tonearm remove it in its box.

Unpack lid and put it aside.

T base:

Remove the foam and lift the main T base (Fig. 3) of turntable carefully as it is heavy and put it on a shelf so that the side with the bearing is situated at 8 o' clock and the side with the tonearm mount at 2' o clock. See Fig 6.



Fig. 6 Position T base + motor tower

Motor tower:

Lift the motor tower with the cable, being careful not to touch the black motor pulley. Position it in the 8 o'clock position in the middle of the shorter length of the T base. Turn the motor tower so that the mains switch faces forwards. The distance between the motor tower and T base should be approximately 10 mm. See Fig. 6.

Bearing oil:

From the oil bottle, fill the bearing hole on the T base with 25 drops from the oil bottle.

Subplatter:

Lift the aluminium subplatter from the box (Fig. 4) being careful not to touch the shaft with any sharp object such as keys, screwdrivers, etc. Remove the protective cover, insert the pointed part of the shaft into the bearing and manually check for free rotation.

Belt:

Place the belt over the subplatter and over the motor pulley. Check by manual rotation that the belt runs smoothly in the middle of the motor pulley groove.

Power connection:

Plug into the mains, being aware that there is no mains connection indicator. Press the black switch and ensure that the belt is running properly.

Platter:

Remove the platter (Fig. 5) from its protective bag. Place the platter carefully on top of the subplatter. Check again the position of the motor pulley in relation to the bottom surface of the platter. Press switch again and check that the platter reaches full speed in about 4 seconds.

Turntable setup:

Ensure that the turntable is levelled horizontally. Tidy up the mains cable that runs away from the signal wires as much as possible.

Tonearm mounting:**Stogi tonearms:**

Follow instructions provided with the tonearm. The brass pillar should be removed from the T base by unlocking it with Allen key (3 mm) at the front end of the longer T base . Notice that the inside hole of the brass pillar is eccentric. This hole should be turned towards the platter bearing.

First put the tonearm into the brass pillar. The rotational position and height of the tonearm has yet to be determined so fix the tonearm pillar only gently with Allen key (3 mm) by fixing two side screws. Return the brass pillar to the T base and note position of the tonearm. Make desired changes (VTA, position) before fixing the tonearm firmly into the brass pillar. The VTA can be adjusted by raising or lowering the brass pillar in the T base, after releasing the screw with Allen key (3 mm).

Other tonearms:

Remove the brass pillar and find underneath two threaded holes. Find the circular brass armbase (optional) with appropriate cutout. Using Allen key (3 mm) and two screws fit this onto the pillar. Insert back into T base and, with tonearm protractor, position the brass plate correctly by rotating the brass pillar while releasing the VTA screw with Allen key (3mm). See Fig. 7. Follow tonearm mounting instructions. It is possible that in some circumstances the lid provided may not fit .

The Rega RB 300 tonearm can fit directly into the hole in the brass pillar. The hole in the brass pillar should be turned away from the platter bearing and a thin tube inserted over the tonearm's base. Finally the tonearm should be fixed by an Allen key into the brass pillar.



Fig. 7 Circular brass armbase

Use and adjustments:

Platter rotation:

Press the black mains switch at the front of the motor tower. Some starting noise may be audible from the belt in the first few weeks of use.

Speed 45 rpm:

The pulley fitted is for 33 rpm. Find the black plastic crown pulley ring which fits over the existing motor pulley increasing the diameter of the motor pulley and bringing the speed up to 45 rpm. To do this the platter must first be removed and, with clean fingers, stretch the belt away from the motor pulley while, with the other hand, pushing down crown pulley ring. Make sure the thicker ridge goes down. See Fig. 8. Return platter. To remove the crown pulley reverse the procedure.



Fig. 8 45 rpm crown ring adaptor (no PS)

Speed adjustment:

The motor tower distance affects the speed very little. A difference of a few mm, keeps the speed tolerances below 0.1%.

VTA adjustment:

Every tonearm mounted on this turntable can be adjusted for VTA. Release the brass pillar with Allen key (3 mm) and hold the tonearm in position while locking it back. It is helpful to mark the height position with a felt pen at the back of the brass pillar.

Clamp (optional):

Simply place the brass clamp on top of the record.

Maintenance:

Mat:

The mat can be cleaned using a cloth roller cleaner.

Bearing:

The oil in the bearing will last for 4 or more years. Running the bearing without oil will do little harm due to the materials used and type of construction.

A few drops of oil can be added after this time but it should be remembered that, when the shaft is re-inserted, the oil level will rise. If any spills out it should be wiped with a soft cloth.

Belt:

Periodically (about once a year) remove the platter and belt. Clean the belt and running surfaces of the motor pulley and subplatter with a soft cloth soaked in alcohol. For best performance replace the belt every three years.

Upgrades: adding second tonearm adaptor, power supply or 12 inch version tonearm are available,

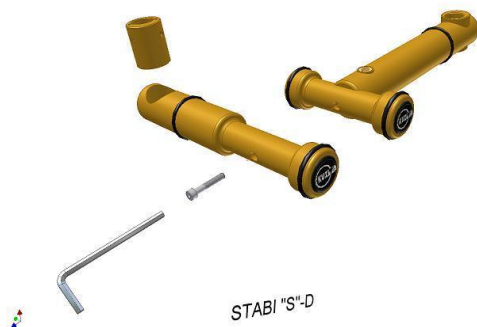
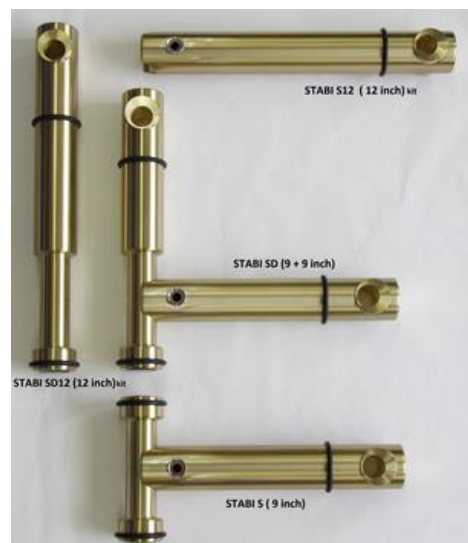

Fig. 9 Second tonearm SD kit



Troubleshooting:

Platter not rotating:

Check the belt.

Check mains connection.

Very slow start:

The belt tension may be out of range. Bring the motor tower away from the T base.

Remove platter and belt and check if the subplatter rotates smoothly.

Transportation:

For short distances remove the platter and belt and ensure that the cartridge is protected. Do not over tilt the T base in case there is oil leakage from the turntable or some tonearms. Fix parts so that they do not slide around during transport.

For longer transportation, however, parts should be replaced, in reverse order, into their original packing, ensuring in particular that protection foam is inserted between parts such as the subplatter, platter and T base. Be sure that the motor pulley is protected. See Fig 3.

Kuzma Ltd

Hotemaze 17A

SI-4205 PREDDVOR

SLOVENIJA

P: + 386 4 25 35 450

F: + 386 4 25 35 454

E mail: kuzmaktd@siol.net

www.kuzma.si